

USER MANUAL



Maxwell Technologies® Ultracapacitor Energy Storage Modules Powered by DuraBlue™ Technology

Module Description	Model Numbers	Associated Datasheet Doc #
48V Module	BMOD0165 P048 C01	3000685.X



Maxwell Technologies, Inc.
Global Headquarters
3888 Calle Fortunada
San Diego, CA 92123
USA
Phone: +1 858 503 3300
Fax: +1 858 503 3301



Maxwell Technologies SA
Route de Montena 65
CH-1728 Rossens
Switzerland
Phone: +41 (0)26 411 85 00
Fax: +41 (0)26 411 85 05



Maxwell Technologies GmbH
Leopoldstrasse 244
80807 München
Germany
Phone: +49 (0)89 4161403 0
Fax: +49 (0)89 4161403 99



Maxwell Technologies Korea Co., Ltd.
Room 1524, D-Cube City
Office Tower, 15F #662
Gyeongin-Ro, Guro-Gu,
Seoul, 152-706
South Korea
Phone: +82 10 4518 9829



Maxwell Technologies
Shanghai Trading Co., Ltd.
Unit A2,C 12th Floor
Huarun Times Square
500 Zhangyang Road,
Pudong New Area
Shanghai 200122,
P.R. China
Phone: +86 21 3852 4000
Fax: +86 21 3852 4099



Maxwell Technologies
Shanghai Representative Office
Unit B 12th Floor
Huarun Times Square
500 Zhangyang Road,
Pudong New Area
Shanghai 200122,
P.R. China
Phone: +86 21 3852 4000
Fax: +86 21 3852 4099

TABLE OF CONTENTS

1	Introduction	3
1.1	<i>Module components and terminology</i>	3
2	Unpacking and handling	4
2.1	<i>Unpacking</i>	4
2.2	<i>Handling</i>	4
3	Installation	5
3.1	<i>Mechanical installation</i>	5
3.1.1	<i>Mounting</i>	5
3.1.2	<i>Vibration and shock</i>	5
3.1.3	<i>Venting</i>	6
3.2	<i>Electrical installation</i>	6
3.2.1	<i>Terminal posts</i>	7
3.2.2	<i>User Interface Connector</i>	8
3.3	<i>Thermal performance</i>	13
4	Operation	14
5	Safety	14
5.1	<i>Discharge procedure</i>	15
6	Maintenance	16
6.1	<i>Routine maintenance</i>	16
7	Storage	17
8	Disposal	17
9	Specification	17
10	Installation checklist	18
11	Examples of installation recommendations	23
12	Types of connections	28
13	Frequently Asked Questions (FAQ)	29
14	Appendix 1: Negative Temperature Coefficient (NTC) values	29
15	Index	32

1 Introduction

The DuraBlue™ energy storage modules are self-contained energy storage devices comprised of individual DuraBlue™ ultracapacitor cells connected in series. The modules include bus bar connections and integrated cell balance voltage management circuitry.

Multiple modules may be connected in series to obtain higher operating voltages, in parallel to provide additional energy storage, or a combination of series/parallel arrangements for higher voltages and energy. Voltage management circuit alarms are designed to warn you if operating limits have been exceeded in an attempt to protect each cell from operating in a damaging overvoltage condition.

1.1 Module components and terminology

For reference only. Module appearance may vary; major components are shown below.

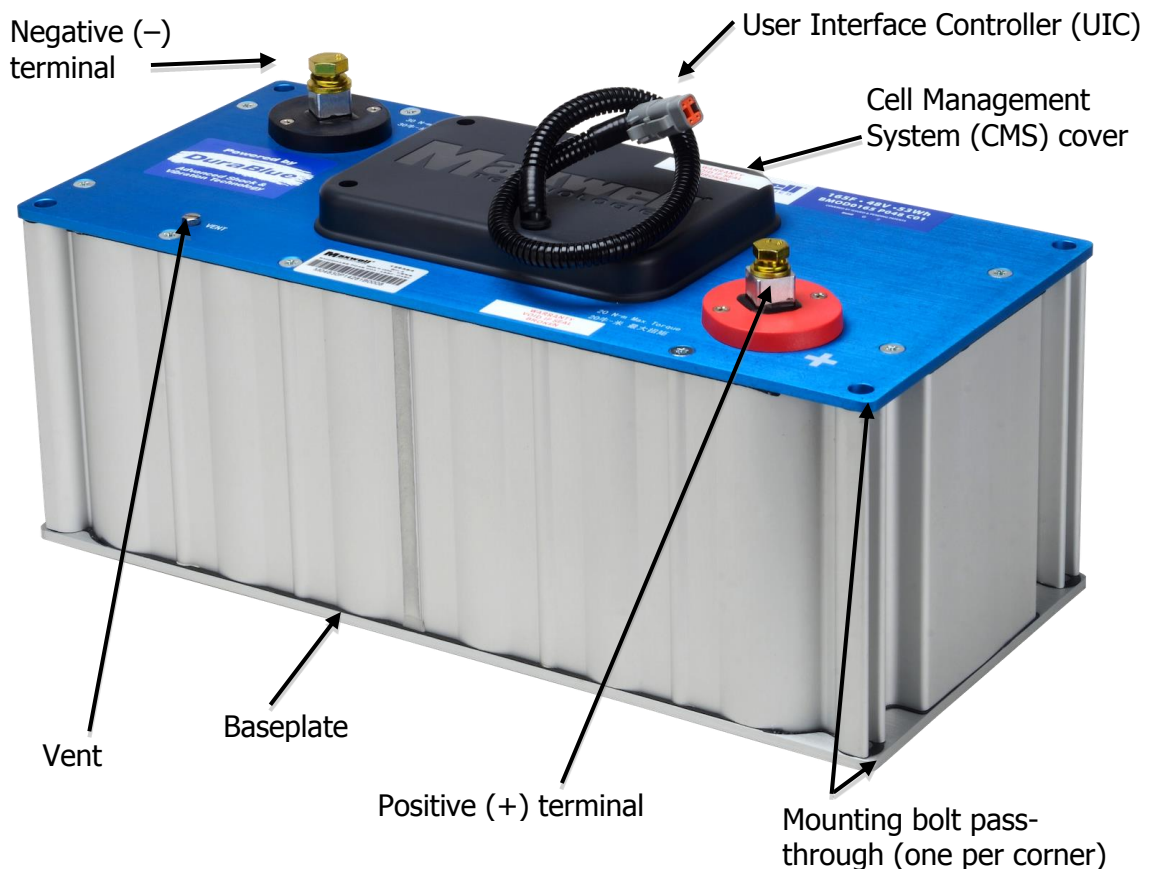

2 Unpacking and handling

2.1 Unpacking

Inspect the shipping packaging for signs of damage prior to unpacking each module. Damage to the packaging or module should be reported to the carrier immediately. Remove each module from the packaging and retain the shipping materials until the module has been inspected and is determined to be operational.

Visit www.maxwell.com and download the appropriate datasheet for your module.

 NOTE	The original shipping materials are approved for both air and ground shipment. When removing the module from the packaging, lift it by the module body, not by the terminal posts.
---	--

Each energy storage module is supplied with one M10 bolt for the negative (–) terminal and one M8 bolt for the positive (+) terminal.

If the unit is found to be defective or any parts are missing, contact your supplier. A Return Material Authorization (RMA) number must be requested and issued by Maxwell prior to returning the unit for repair or replacement.

2.2 Handling

Maxwell ultracapacitor modules are designed to provide years of trouble-free operation. Proper handling is required to avoid damage to the module. In particular, the following handling precautions should be observed:

- Do not stack modules once they have been removed from their shipping packaging.
- Do not drop modules. Internal damage may occur that will not be visible from the module exterior.
- Do not step on modules.
- Protect the module from impact.

3 Installation

3.1 Mechanical installation

3.1.1 Mounting

Modules can be mounted and operated in any orientation. Two mounting surfaces are available: the top and the bottom surfaces of the module. These top and bottom plates are designed to support the module with no additional mechanical contact.

For best results, mount the modules in locations where they are not directly exposed to harsh environments. In particular, always avoid areas of direct splash. In systems that operate at voltages in excess of 60V, appropriate protection and sealing should be used on both module terminals to avoid shock hazards and corrosion.

Use one high-quality mounting bolt per corner:

- Metric: Class 8.8 or 10.9, M8
- Standard: Grade 5 or 8, 5/16"

Each bolt should reach completely through the mounting bolt pass-through on the module corner (see the "Module components and terminology" section on page 3). Use the appropriate bolt length for the specific installation; include length for the use of lock washers or lock nuts.

Installation should not exert bending or twisting torque to the module enclosure. Torque may be caused by uneven mounting points or surfaces. Ensure that the module's mounting points are all flat within ± 1 mm. Refer to the "Installation checklist" section on page 18 for specific examples.

The figure below illustrates flatness.

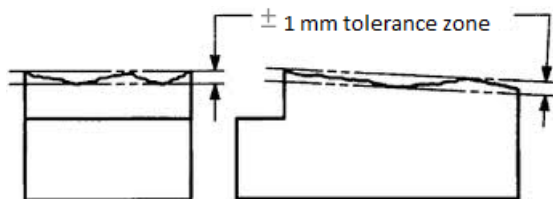

Figure 1. Flatness example

3.1.2 Vibration and shock

To ensure successful, long-life operation, please ensure that the vibration and shock experienced by the module is compatible with the accelerated vibration and shock qualification standard referenced on the module datasheet.

3.1.3 Venting

Each module is provided with a threaded vent hole in the top plate. The module is shipped from the factory with a plug in this vent hole. Use of the vent is optional: it is designed to relieve gas pressure that may build up within the module in the event of cell failure.

For more information about this gas, contact your Maxwell representative or download the cell Safety Data Sheet from www.maxwell.com

If your application recommends or requires remote venting, contact your Maxwell representative to receive a threaded hose barb for each module. Replace the vent plug with the hose barb and attach a 5/32-inch (4 mm) ID hose, preferably Teflon or polypropylene. Route the hose to a safe venting location.

3.2 Electrical installation

WARNING



To avoid arcing, the energy storage module should be in a discharged state and the system power disconnected during installation. The module is shipped discharged and with a shorting wire connecting the positive (+) and negative (–) terminals. You must remove the shorting wire before making the electrical connections.

To provide the lowest possible equivalent series resistance, the energy storage modules are not fused. Care should be taken within the application to prevent excessive current flow as required. Excessive current and/or duty cycle will result in overheating the module, which will cause irreparable damage. Please refer to the product datasheet for maximum allowable RMS current values.

Module-to-module cabling should be sized for the application's peak and/or RMS current. Undersized cables may cause excessive cable or interconnect temperature rise and system electrical resistance. High-resistance wiring/cables or module power connections will increase terminal cell temperature and degrade module lifetime and long-term performance. Refer to applicable wire sizing guides. Wire temperature must not exceed module temperature.

NOTE

The module chassis should be grounded to the system chassis through any of the module mounting bolt pass-through holes. Refer to applicable ground wiring guides and standards for the application.

The anodized coating of the module on the ground connection surface must be removed to ensure good electrical contact. Apply a layer of high conductivity anti-oxidant joint compound between the mating surfaces (IDEAL Noalox® Anti-Oxidant Compound or equivalent).

3.2.1 Terminal posts

The positive (+) and negative (-) terminals of the module consist of internally threaded aluminum posts, which are designed to connect directly to ring lugs or bus bars. The positive (+) terminal uses a M8 bolt; the negative (-) terminal uses a M10 bolt. Maximum thread engagement on module terminals cannot exceed thread depth (Z) indicated on the datasheet. The minimum thread engagement (TE) must be at least 1.5 times the bolt diameter. If the combined thickness (X) of ring lugs or bus bars and lock washers results in thread engagement less than 1.5 times bolt diameter, a longer bolt than the one supplied with the module must be selected. See the illustration below for details.

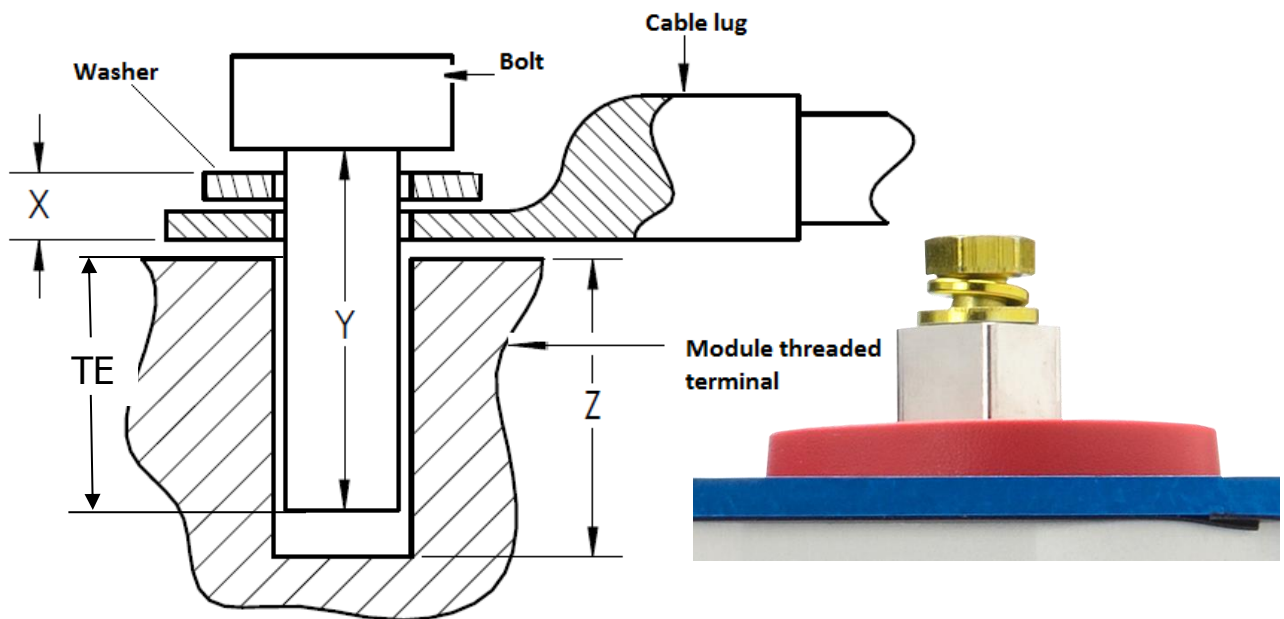

Figure 2: Module terminal thread engagement diagram and overview

- In the diagram above:
- TE = Thread engagement
- X = Washer and cable lug thickness
- Y = Threaded bolt length
- Z = Module terminal thread depth

The terminal contact surface should be cleaned with a light abrasive such as Scotch-Brite™ to remove any oxidation prior to cable/bus bar installation. Apply a light layer of high conductivity anti-oxidant joint compound between the mating surfaces (IDEAL Noalox® Anti-Oxidant Compound or equivalent). This corrosion removal/prevention process should help ensure a long-life, low-resistance electrical connection. Avoid applying joint compound to bolt threads as this may result in excessive torque and stripped terminal threads. Excessive use of joint compound may result in high-voltage isolation faults or failures. Use joint compound with appropriate care.

Lock washers are recommended for long-term, reliable connections.

	Do not use impact tools (e.g. hammers) to install or remove terminal bolts. Serious damage may occur.
	The positive (+) and negative (-) terminal bolts are different sizes and have different torque values. When tightening the terminal bolts, do not exceed the recommended torque values for each bolt. These values are specified in the datasheet and printed on the top cover of the module.

As in any electrical system, proper cable restraint is required. Cables should be installed so they do not exert bending or twisting torque on the terminals, and should be restrained within 25 cm of the terminal before bending the cable in any direction. For an example of this configuration, refer to the “Examples of installation recommendations” section on page 23. High-vibration environments may require additional cable restraints.

3.2.2 User Interface Connector

The User Interface Connector (UIC) of the module provides module temperature and overvoltage alarm feedback. It is critical that the user constantly monitors every module in their system for both overvoltage alarms and module temperature signals to help ensure safe, long-life operation. The UIC appearance and pin functions are shown below in Figure 3.

When designing the interface to your system, use Deutsch-type connectors and size 20 solid pins. Strip 4 mm – 5.5 mm of insulation from the wire and crimp pin to wire. Inspect crimp to ensure all wire strands are captured and wire is visible through the inspection window on the pin. Recommended crimping tools are shown in the table below.

Manufacturer	Pin size	Wire size	Crimping tool
Deutsch	20	20 AWG	HDT-48-00
Amphenol	20	20 AWG	CA-5D12
For reference only; subject to change by manufacturer. Always follow the manufacturer’s assembly and use guidelines.			

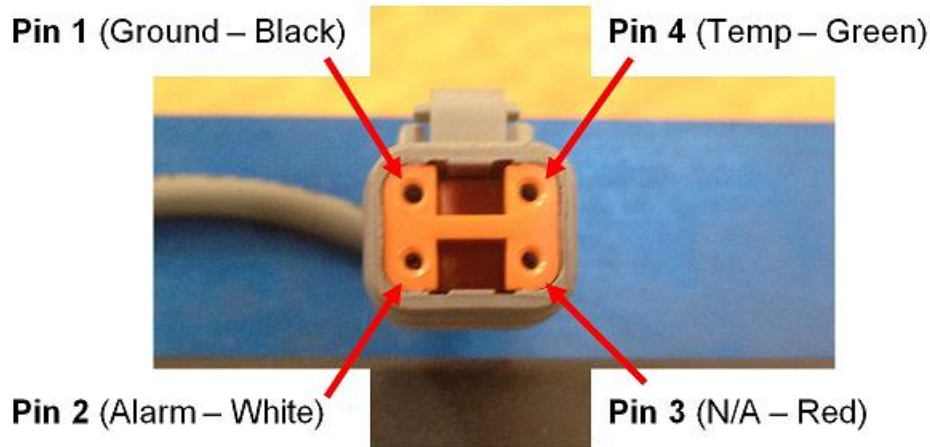



Pin #	Wire color	Pin out designation
1	Black	Ground
2	White	Overvoltage alarm
3	Red	Not used
4	Green	Temperature

Figure 3: User Interface Connector and pin designations

For multi-module strings, it is recommended that the user monitor overvoltage alarm and temperature signal for every module. Individual monitoring of overvoltage alarms and temperature signals will improve system safety and diagnostic capability in the field.

3.2.2.1 Overvoltage alarm detection

The overvoltage alarm should be used as a signal to the system electronics to stop charging in order to protect cells from damage. Figure 4 shows an example of how customers may read this alarm.

	Selecting resistor values below the minimum recommended value may result in damage to the alarm circuit and/or excessive sensor power consumption.
	For high-electrical-noise environments, Maxwell recommends use of common noise-reduction techniques, such as an isolated current loop detection circuit for the overvoltage alarm. See page 11, Figure 6 for an example.

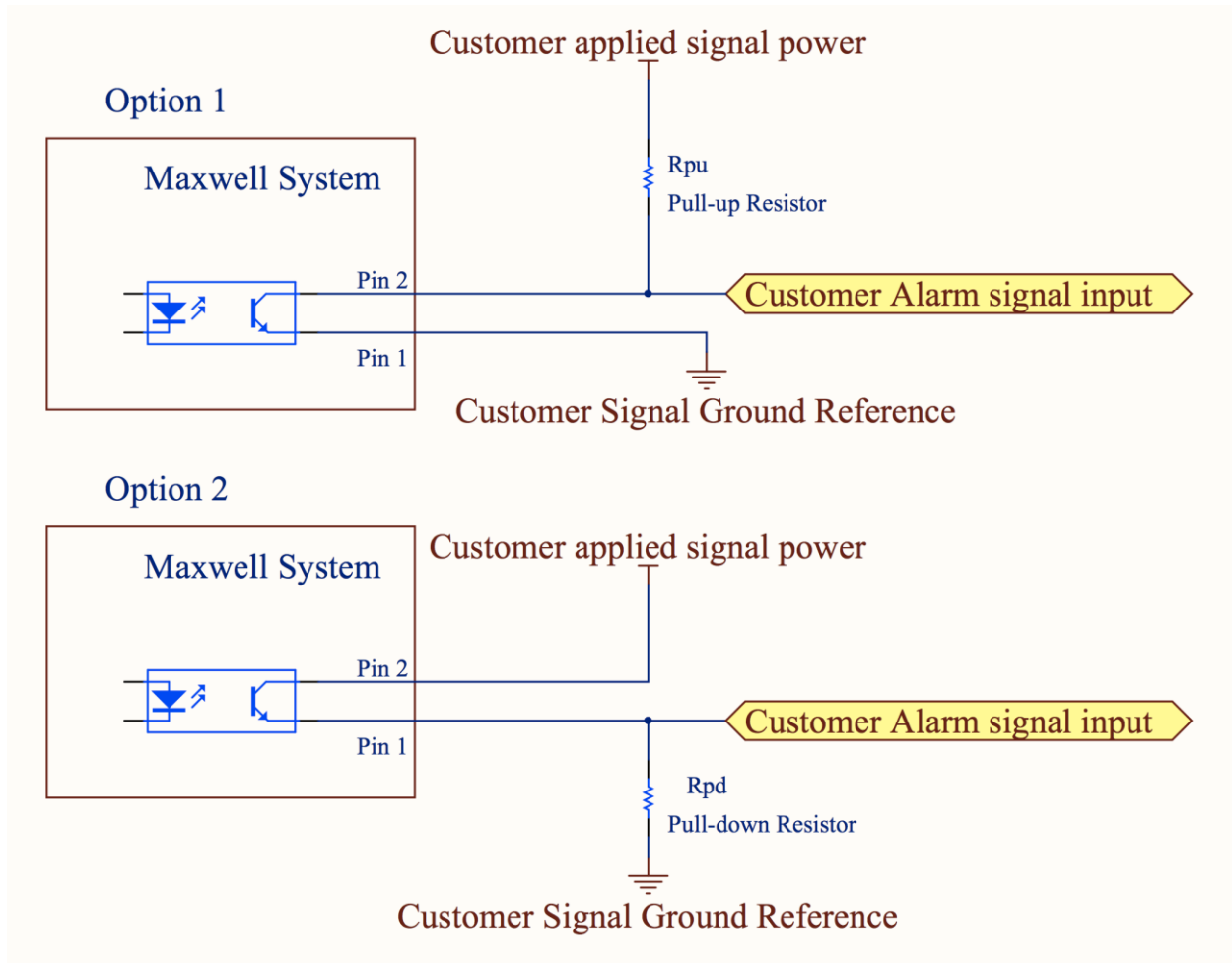

Figure 4: Overvoltage alarm circuit examples

Customer applied signal voltage (V)	Recommended pull-up or pull-down resistor value (for $I_C=5\text{mA}$)
5 V	1.0 k Ω
10 V	2.0 k Ω
15 V	3.0 k Ω
20 V	4.0 k Ω
25 V	5.0 k Ω
30 V	6.0 k Ω
35 V	7.0 k Ω

Figure 5: Voltage and resistor values for use with the Overvoltage alarm

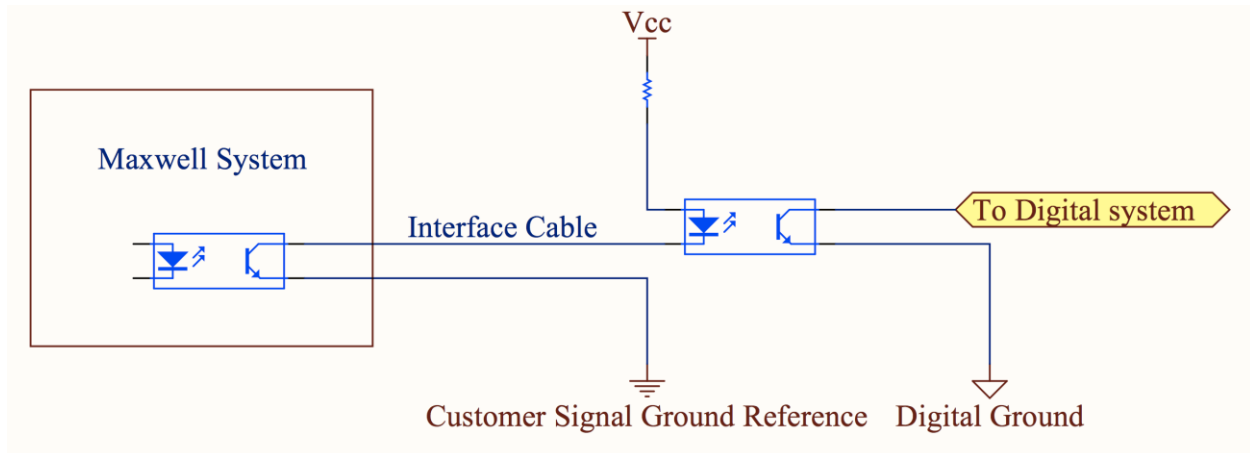



Figure 6: Example schematic for overvoltage alarm circuit in high-electrical-noise environments

3.2.2.2 Module temperature signal

A single NTC (Negative Temperature Coefficient) thermistor is mounted to the end of a single cell in the center of the module; its reading is used to indicate average module temperature. The resistance of this thermistor varies with temperature.

The circuit diagrams below offer examples and suggestions about how customers might interface and read the module variable resistance temperature sensor.

The temperature output operates at any module voltage including zero volts.

	<p>A table of detailed values of thermistor resistance as a function of temperature is given in Appendix 1, page 29.</p>
	<p>Different applied signal voltages will require different resistor values (see Figure 8). Selecting resistor values lower than those recommended may result in excessive current through the thermistor that may cause sensor failure and/or excessive sensor self-heating that will result in inaccurate temperature readings.</p>

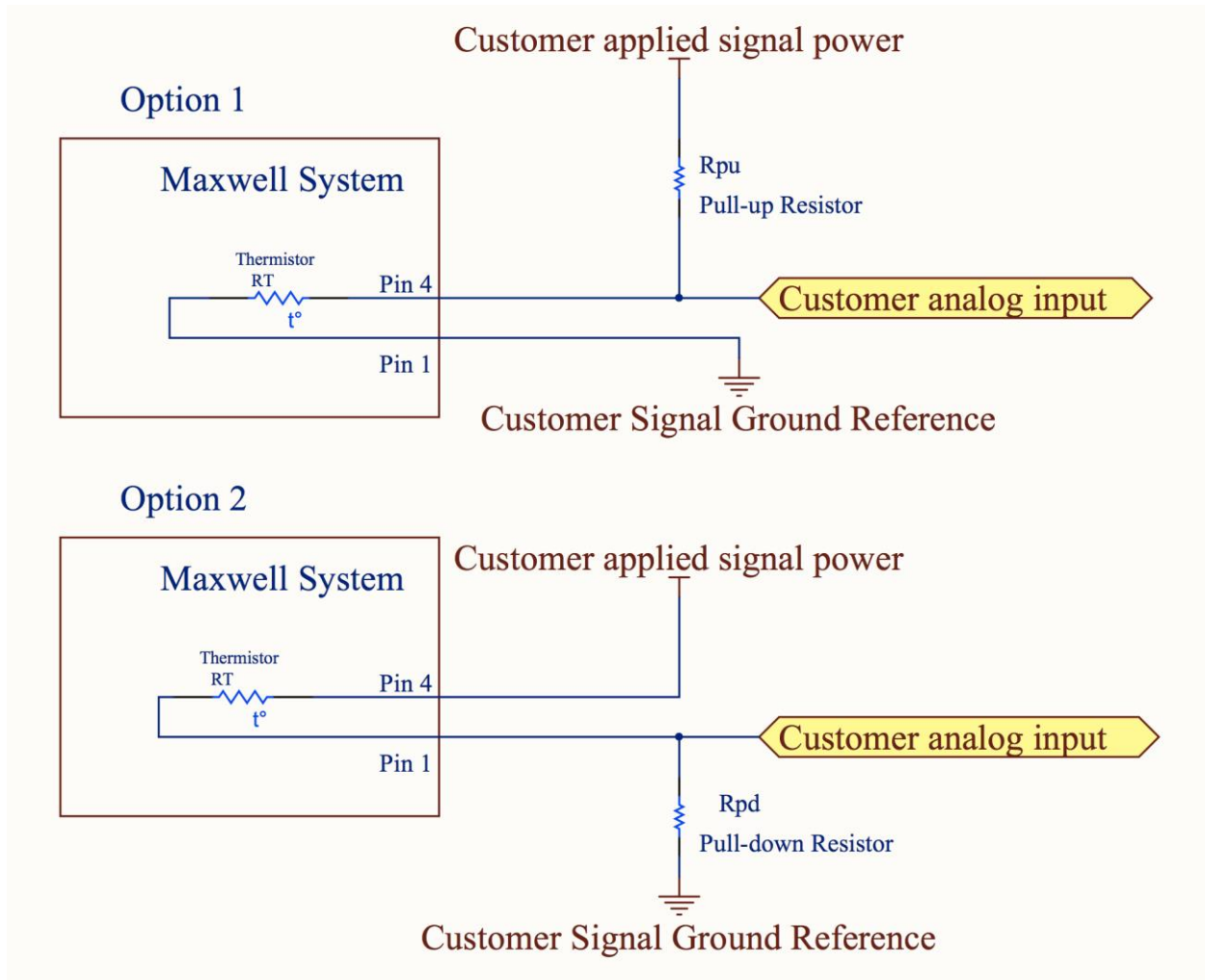

Figure 7: NTC thermistor monitoring examples

Customer applied signal voltage	Recommended pull-up or pull-down resistor value
5 VDC	10 kΩ
12 VDC	38 kΩ
24 VDC	86 kΩ

Figure 8: Recommended voltage and resistor values for use in the thermistor circuit

3.3 Thermal performance

The Maxwell energy storage modules generate small amounts of heat during use. As with most electronic components, reduced operating temperature will extend the service life. In most applications, natural air convection should provide adequate cooling at the rated module current. The majority of module heat rejection occurs from the flat top and bottom cover plates. Increasing airflow over these two module surfaces will further improve module heat rejection performance and reduce operating temperature.

The thermal resistance, R_{TH} , of the units has been experimentally determined assuming free convection at ambient temperature ($\sim 25\text{ }^{\circ}\text{C}$). The R_{TH} value provided on the datasheet is useful for determining the operating limits for the units.

Using the R_{TH} value, a module temperature rise can be determined based upon any current and duty cycle. The temperature rise can be expressed by the following equation.

$$\Delta T = I^2 R_{ESR} R_{TH} d_f$$

where:

- I = RMS current (amps)
- R_{ESR} = equivalent series resistance, R_{DC} (ohms)
- R_{TH} = thermal resistance ($^{\circ}\text{C}/\text{W}$)
- d_f = duty cycle fraction

The ΔT value calculated above plus ambient temperature should remain below the specified maximum operating temperature for the module (for maximum operating temperature, refer to the module datasheet) as measured by the thermistor output. If supplemental cooling methods are employed, it may possible to operate at higher currents or duty cycles than if cooling occurs by natural air convection only.

Thermal capacitance is a parameter that is useful in calculating or estimating how fast the module will reach its stable temperature state under given I_{RMS} . This value can be estimated by the following equation.

$$t = 5C_{TH} R_{TH}$$

where:

- t = time (sec.)
- C_{TH} = thermal capacitance, (J/ $^{\circ}\text{C}$)
- R_{TH} = thermal resistance ($^{\circ}\text{C}/\text{W}$)

4 Operation

The module should only be operated within specified voltage and temperature ratings specified on the datasheet. Determine whether current limiting is necessary based on the current ratings of attached components. Observe polarity indicated on module. Do not reverse polarity.

5 Safety

DANGER



HIGH VOLTAGE HAZARD

Never touch the positive (+) or negative (–) terminals as the module can be charged and cause **fatal electrical shocks**. Always verify that the module is fully discharged before manipulating the module. Refer to the instructions in section 5.1 below for the manual discharge procedure.

- Do not operate unit above the specified voltage.
- Do not operate unit above the specified temperature rating.
- Do not touch terminals with conductors while the module is charged. Serious burns, shock, or material fusing may occur.
- Protect surrounding electrical components from incidental contact.
- Provide sufficient electrical isolation when working above 50 VDC.
- Prior to installation in or removal from the system, fully discharge the module to guarantee the safety of all personnel.

WARNING



A fully discharged module may “bounce back” if it is stored without a shorting wire connected to the positive (+) and negative (–) terminals. This bounce back can be as much as 6 V and could cause dangerous electrical shocks, especially in multi-module strings.

5.1 Discharge procedure

To discharge an individual module:

1. Using a voltmeter, measure the voltage between the positive (+) and negative (-) terminals.
2. If the voltage is above 2 V, a power resistor (not supplied with the module) may be connected between the terminals to discharge the module. Proper care needs to be taken in the design and construction of such a resistor. The discharge time, current, power and temperature will depend on the resistor value and the amount of energy to be discharged.

NOTE

Customers may also use a DC electronic load tool to support the safe/controlled discharge of individual modules prior to service (for example, the BK Precision DC Electronic Load Model 8500 or a similar tool).



300 W

3. If the voltage is under 2 V, connect a shorting wire between the positive (+) and negative (-) terminals.
4. The module is now safe for handling. However, leave the shorting wire connected **at all times** until you are installing the module and connecting power cables to the terminals.

6 Maintenance

Prior to removal from the system, cable removal, or any other handling ensure that the energy storage module is completely discharged in a safe manner. The stored energy and the voltage levels may be lethal if mishandling occurs. Maintenance should only be conducted by trained personnel on discharged modules (see the “Discharge procedure” section 5.1 above).

6.1 Routine maintenance

WARNING

<p>Do not use high-pressure sprays or immersion to clean the module. Keep excess amounts of water away from the cell management system cover and power terminals (see the “Module components and terminology” section on page 3 for details).</p>

	Outside use / dirty / dusty / high-vibration environment	Inside use / clean / low-vibration environment
Use a damp cloth to clean the exterior of the module and remove dirt and grime.	At least every 6 months (more frequently in very dusty-dirty environments)	Annually
Use a calibrated torque wrench to check mounting fasteners for proper torque.		
Inspect housing for signs of internal damage.		
Check signal/ground connections for false signals or shock hazards.		

7 Storage

The discharged module can be stored in the original package in a dry place. Discharge a used module prior to stock or shipment. After you discharge the module, connect a shorting wire between the positive (+) and negative (–) terminals to maintain a short circuit.

For more information about discharging a module, see the “Discharge procedure” section on page 15.

8 Disposal

Do not dispose of module in trash. Dispose of according to local regulations.

9 Specification

Refer to datasheets at our website, www.maxwell.com, for specifications of each product.

10 Installation checklist



The following checklist details best practices and requirements for the 48V energy storage module. Requirements are highlighted in the table for easy identification.

MOUNTING MODULES	
 REQUIREMENT	Modules must be fastened to a flat mounting surface using all 4 mounting bolt pass-through holes available on the module. No deformation of the module's bottom or top plates should be allowed.
BEST PRACTICE	If customers use multi-level racks to support Maxwell modules and other components Maxwell recommends the ultracapacitors be placed at the lowest level to reduce vibration exposure.
BEST PRACTICE	<p>Module support racks are normally manufactured from angle iron or tubing materials. Design must consider thickness of support tubing/angle iron, rigidity and number of attachment points to ensure sufficient rigidity to minimize vibration resonance, which may amplify shock and vibration transmitted to the modules.</p> <p>Surface mounting areas must be flat to avoid deformation of the modules once installed. Maxwell recommends the addition of diagonal cross-bracing to racks wherever possible for added rigidity. Maxwell can offer guidance on rack design if requested.</p>
BEST PRACTICE	For rack mounting, Maxwell suggests that racks are securely attached to the main steel chassis or frame of the vehicle. Mounting racks only to vehicle wooden flooring is not acceptable.
BEST PRACTICE	Rack bracing to side or back walls of the vehicle is also recommended for added rigidity.
BEST PRACTICE	Maxwell suggests that each module be fastened using high-quality fasteners. <ul style="list-style-type: none"> • Metric: Class 8.8 or 10.9, M8 • Standard: Grade 5 or 8, 5/16" Use the appropriate bolt length for the specific installation; include length for the use of lock washers or lock nuts.

CABLING CONNECTIONS	
 REQUIREMENT	Maxwell requires that the main positive (+) and negative (-) power cables are properly restrained to prevent movement and stress to the terminals of the module. Terminal bolts should be tightened using a calibrated torque wrench to no more than the maximum torque values printed on the top plate of each module. The positive (+) and negative (-) terminals have different torque values.
BEST PRACTICE	Maxwell suggests that interconnecting cables between modules on the same level of the rack be kept as short as practically feasible. However, cable length must not be so short that it applies bending stress to the terminals. (See the "Examples of installation recommendations" section on page 23 for clarification.)
BEST PRACTICE	Maxwell recommends that customers avoid attaching more than one cable per terminal with a maximum of two cables per terminal for parallel module configurations. Multiple cable connections may be more likely to become loose under vibration and damage terminal connections. Observe the minimum thread engagement specifications shown in Figure 2 on page 7.
BEST PRACTICE	Maxwell recommends that customers using their own fasteners use high-quality hardware. (Metric: Class 8.8 or higher). Bolt lengths should be selected based on thread depth and cable lug thickness to avoid bottoming out or insufficient thread engagement. See Figure 2, page 7.
BEST PRACTICE	Maxwell recommends that each module case be grounded to the vehicle chassis ground for optimal service personnel safety.



MONITORING	
 REQUIREMENT	Maxwell requires that the vehicle monitoring system use the provided overvoltage and temperature signals from the module. Additionally, the monitoring system must be able to indicate to the driver of the vehicle that an overvoltage or over temperature condition has occurred or is occurring.
BEST PRACTICE	Maxwell recommends that an alarm response/control plan is available to the driver in the event of an overvoltage or over temperature event occurs so the driver or system can react appropriately to the situation. These response plans should include actions required following a collision with another vehicle to inspect the ultracapacitor system to verify there are no signs of physical damage prior to attempting to restart the vehicle.
BEST PRACTICE	Maxwell suggests that a fire suppression system and fire retardant materials be used in the high-voltage/high-power hybrid system compartment.





THERMAL CONTROL	
BEST PRACTICE	Maxwell recommends that the module compartment is vented to the exterior of the vehicle and has an ambient temperature control system that regulates compartment temperature to <35 °C for extended module life.
BEST PRACTICE	Maxwell recommends that the output of the temperature thermistor built into each module is monitored separately by the vehicle monitoring system. Maxwell's specification for maximum operating cell temperature is 65 °C. Cell temperature should ideally be maintained at or below 45 °C to maximize cell lifetime.

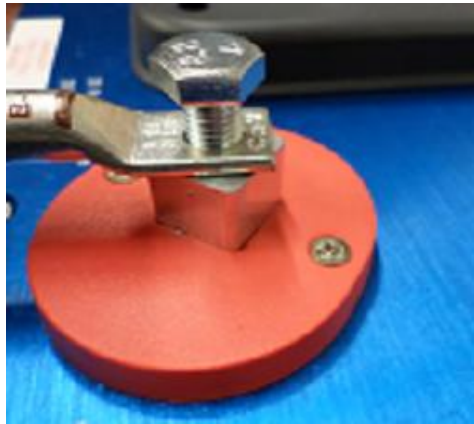

PROCEDURE & PROTOCOL	
 <p>REQUIREMENT</p>	<p>Maxwell requires that the vehicle maintenance manual include the periodic maintenance schedule for the ultracapacitor modules, as shown in the "Routine maintenance" section on page 16. In particular, it should include the recommended interval for checking both terminal bolts and mounting bolts on the Maxwell ultracapacitor modules are torqued to recommended torque specification.</p>
 <p>REQUIREMENT</p>	<p>Maxwell requires that the surfaces of modules be cleaned to remove accumulated dirt, dust, and other debris to prevent dielectric breakdown and ensure optimal thermal performance. Maintenance intervals will vary by application. See the "Routine maintenance" section on page 16 for details.</p>
 <p>REQUIREMENT</p>	<p>Maxwell requires that the vehicle company and end user personnel be trained on proper safety, maintenance, handling and removal/re-installation of ultracapacitor modules to ensure safe, reliable operation over the application lifetime.</p>
<p>BEST PRACTICE</p>	<p>Maxwell strongly recommends that the vehicle company provide their end customers with reaction plans or protocols to follow if the hybrid system suffers a malfunction.</p> <p>These reaction plans should include plans in the event of the vehicle monitoring system advising the vehicle operator that an overvoltage alarm or high temperature signal is occurring, along with actions required following a collision with another vehicle to ensure the hybrid system is undamaged and fully operational.</p>

INTEGRATION	
BEST PRACTICE	Maxwell recommends that the hybrid system integrator or vehicle manufacturer characterize vibration levels experienced during a typical vehicle drive cycle. Vibration levels should be measured at the support structure mounting location, and at each level of the mounting rack(s) to evaluate shock and vibration levels along with possible amplification that must be minimized.
BEST PRACTICE	Maxwell recommends that high-voltage cable and ground routing be separated from low-voltage cabling and communication to reduce electrical noise source that can interfere with overvoltage alarm and temperature signal quality.

11 Examples of installation recommendations

INCORRECT METHOD 	CORRECT METHOD 
 <p>The lug and hole size is too large. This may result in a poor electrical connection or unreliable bolted joint connection.</p>	 <p>The lug and hole size closely match the power terminal and bolt size.</p> <p>Lock washer not shown to give clear view of lug hole size. Maxwell recommends using lock washers with the terminal bolts.</p>

INCORRECT METHOD 	CORRECT METHOD 
 <p data-bbox="188 1003 769 1108">The cable shown above is too small for the terminal lug. This may result in an unreliable or high-resistance cable assembly.</p>	 <p data-bbox="797 995 1414 1066">The cable and cable lug match to help ensure a reliable, low-resistance cable assembly.</p>

INCORRECT METHOD 	CORRECT METHOD 
<div data-bbox="193 499 771 735" data-label="Image"> </div> <p data-bbox="185 768 760 871">This example shows cables that are too short, potentially causing excessive terminal stress.</p> <div data-bbox="193 940 771 1234" data-label="Image"> </div> <p data-bbox="185 1268 737 1446">The example above shows a cable service loop that is too long and unsecured. This causes wasted cable/cost, increased cable resistance, and increased chance for wire chafing/rubbing during operation.</p>	<div data-bbox="805 499 1433 730" data-label="Image"> </div> <p data-bbox="797 768 1417 976">The picture above shows an appropriate length of cable. This allows for reasonable manufacturing and assembly tolerance. The cable is also restrained near the center to avoid possible cable chafing or rubbing against the module top plate during vibration.</p>

INCORRECT METHOD







The picture above shows an incorrect low-voltage routing. The low-voltage wire is not restrained and may rub through against the module top cover or support structure causing false alarms or failure to alarm.

CORRECT METHOD



Low-voltage cable is carefully routed and secured to the top cover of the module, reducing the chance of wire chafing failures.

INCORRECT METHOD 	CORRECT METHOD 
 <p data-bbox="186 1413 751 1654">The pictures above show the module support structure is not parallel/flush with the module baseplate. This will cause the module to become over-stressed when the mounting bolt is tightened. Re-evaluate the mounting structure design and or assembly fixture.</p>	 <p data-bbox="799 919 1401 1024">The picture above shows a module baseplate that is parallel/flush with the support structure before the mounting bolt is secured.</p>

12 Types of connections

This section shows types of cable connections for modules, including serial and parallel.

NOTE Alarm/temperature monitoring cables must be connected prior to final system startup.

Serial connections

The pictures below show serial connections. You can connect modules in series to obtain higher operating voltages.



Parallel connection

The picture below shows a parallel connection, which can be used to provide additional energy storage. In parallel connections you can connect up to two cable lugs to a single terminal.



13 Frequently Asked Questions (FAQ)

This section provides answers to common questions about the product.

QUESTION: What are the important installation differences between Maxwell's new module and previous designs?

ANSWER:

1. The positive (+) and negative (-) terminals are slightly offset, which may require modifications to power cable length.
2. Longer mounting bolts are required to secure the module to the vehicle support structure. The bolt now passes through the module's top and bottom cover plates rather than just the lower mounting plate.

14 Appendix 1: Negative Temperature Coefficient (NTC) values

Consult this table for thermistor values as a function of temperature.

Temp (°C)	Temp (°F)	Resistance ratio Rt/R@+25°C	TC (%/°C)	10,000 Ω Ω
-40	-40.0	33.647900	-6.66	336,479.00
-39	-38.2	31.490400	-6.61	314,904.00
-38	-36.4	29.484800	-6.56	294,848.00
-37	-34.6	27.619400	-6.52	276,194.00
-36	-32.8	25.883800	-6.47	258,838.00
-35	-31.0	24.268100	-6.43	242,681.00
-34	-29.2	22.763200	-6.39	227,632.00
-33	-27.4	21.361000	-6.34	213,610.00
-32	-25.6	20.053900	-6.30	200,539.00
-31	-23.8	18.834900	-6.26	188,349.00
-30	-22.0	17.697400	-6.21	176,974.00
-29	-20.2	16.635600	-6.17	166,356.00
-28	-18.4	15.644100	-6.13	156,441.00
-27	-16.6	14.717700	-6.09	147,177.00
-26	-14.8	13.851800	-6.05	138,518.00
-25	-13.0	13.042100	-6.01	130,421.00
-24	-11.2	12.284700	-5.97	122,847.00
-23	-9.4	11.575900	-5.93	115,759.00
-22	-7.6	10.912200	-5.89	109,122.00
-21	-5.8	10.290600	-5.85	102,906.00
-20	-4.0	9.708100	-5.81	97,081.00

Temp (°C)	Temp (°F)	Resistance ratio Rt/R@+25°C	TC (%/°C)	10,000 Ω Ω
-19	-2.2	9.162100	-5.77	91,621.00
-18	-0.4	8.650100	-5.74	86,501.00
-17	1.4	8.169800	-5.70	81,698.00
-16	3.2	7.719000	-5.66	77,190.00
-15	5.0	7.295700	-5.63	72,957.00
-14	6.8	6.898200	-5.59	68,982.00
-13	8.6	6.524600	-5.55	65,246.00
-12	10.4	6.173600	-5.52	61,736.00
-11	12.2	5.843400	-5.48	58,434.00
-10	14.0	5.532900	-5.45	55,329.00
-9	15.8	5.240700	-5.41	52,407.00
-8	17.6	4.965600	-5.38	49,656.00
-7	19.4	4.706600	-5.34	47,066.00
-6	21.2	4.462600	-5.31	44,626.00
-5	23.0	4.232700	-5.28	42,327.00
-4	24.8	4.015900	-5.24	40,159.00
-3	26.6	3.811500	-5.21	38,115.00
-2	28.4	3.618700	-5.18	36,187.00
-1	30.2	3.436800	-5.15	34,368.00
0	32.0	3.265000	-5.11	32,650.00
1	33.8	3.102900	-5.08	31,029.00
2	35.6	2.949800	-5.05	29,498.00
3	37.4	2.805200	-5.01	28,052.00
4	39.2	2.668500	-4.98	26,685.00
5	41.0	2.539200	-4.95	25,392.00
6	42.8	2.417000	-4.92	24,170.00
7	44.6	2.301300	-4.89	23,013.00
8	46.4	2.191800	-4.86	21,918.00
9	48.2	2.088200	-4.83	20,882.00
10	50.0	1.990100	-4.80	19,901.00
11	51.8	1.897100	-4.77	18,971.00
12	53.6	1.809000	-4.74	18,090.00
13	55.4	1.725500	-4.71	17,255.00
14	57.2	1.646300	-4.69	16,463.00
15	59.0	1.571200	-4.66	15,712.00
16	60.8	1.499900	-4.63	14,999.00
17	62.6	1.432300	-4.60	14,323.00
18	64.4	1.368100	-4.57	13,681.00
19	66.2	1.307200	-4.54	13,072.00
20	68.0	1.249300	-4.52	12,493.00
21	69.8	1.194200	-4.50	11,942.00
22	71.6	1.141900	-4.47	11,419.00
23	73.4	1.092200	-4.44	10,922.00
24	75.2	1.045000	-4.41	10,450.00
25	77.0	1.000000	-4.39	10,000.00
26	78.8	0.957200	-4.36	9,572.00

Temp (°C)	Temp (°F)	Resistance ratio Rt/R@+25°C	TC (%/°C)	10,000 Ω Ω
27	80.6	0.916500	-4.34	9,165.00
28	82.4	0.877700	-4.31	8,777.00
29	84.2	0.840800	-4.28	8,408.00
30	86.0	0.805700	-4.26	8,057.00
31	87.8	0.772200	-4.24	7,722.00
32	89.6	0.740200	-4.22	7,402.00
33	91.4	0.709800	-4.18	7,098.00
34	93.2	0.680800	-4.16	6,808.00
35	95.0	0.653100	-4.14	6,531.00
36	96.8	0.626700	-4.12	6,267.00
37	98.6	0.601500	-4.09	6,015.00
38	100.4	0.577500	-4.07	5,775.00
39	102.2	0.554500	-4.05	5,545.00
40	104.0	0.532600	-4.02	5,326.00
41	105.8	0.511700	-4.00	5,117.00
42	107.6	0.491700	-3.99	4,917.00
43	109.4	0.472500	-3.96	4,725.00
44	111.2	0.454300	-3.93	4,543.00
45	113.0	0.436800	-3.91	4,368.00
46	114.8	0.420100	-3.89	4,201.00
47	116.6	0.404100	-3.87	4,041.00
48	118.4	0.388800	-3.85	3,888.00
49	120.2	0.374200	-3.82	3,742.00
50	122.0	0.360200	-3.80	3,602.00
51	123.8	0.346800	-3.78	3,468.00
52	125.6	0.334000	-3.76	3,340.00
53	127.4	0.321700	-3.75	3,217.00
54	129.2	0.309900	-3.73	3,099.00
55	131.0	0.298600	-3.70	2,986.00
56	132.8	0.287800	-3.68	2,878.00
57	134.6	0.277400	-3.66	2,774.00
58	136.4	0.267500	-3.64	2,675.00
59	138.2	0.257900	-3.63	2,579.00
60	140.0	0.248800	-3.60	2,488.00
61	141.8	0.240000	-3.58	2,400.00
62	143.6	0.231600	-3.56	2,316.00
63	145.4	0.223500	-3.56	2,235.00
64	147.2	0.215700	-3.52	2,157.00
65	149.0	0.208300	-3.50	2,083.00

15 Index

- Anodized coating
 - Safe removal, 7
- Cable restraint
 - Guidelines, 8
- Cable restraints
 - Examples, 8, 19, 23
 - In high vibration environments, 8
- Circuit diagrams
 - Reading module variable resistance temperature sensor, 11
- Cleaning
 - Terminal contact surface, 8
- Cooling methods, 13
- Current flow, 6
- dangerous electrical shocks, 14
- DC electronic load tool, 15
- Defective parts
 - Who to contact, 4
- Discharge an individual module, 15
- Flatness, 5
 - Illustration, 5
- Handling modules
 - Precautions, 4
 - Proper techniques, 4
- HIGH VOLTAGE HAZARD, 14
- High-vibration environments, 8
- Installation
 - Flatness of surfaces, 5
 - Mechanical, 5
 - Mounting surfaces, 5
 - Protection and sealing, 5
- Joint compound
 - Application, 8
 - Excessive use. *See*
- Lock washers, 8
- Measuring module voltage, 15
- Module chassis
 - Grounding, 7
- Module may “bounce back, 14
- Module temperature
 - Average, 11
 - Monitoring, 8
- Module terminal thread depth, 7
- module variable resistance temperature sensor, 11
- Module-to-module cabling, 6
 - Sizing, 6
- Mounting surfaces, 5
- Negative Temperature Coefficient, 11
- Overvoltage alarm
 - Detection, 9
 - Example of how to read, 9
- Overvoltage alarm feedback
 - Monitoring via UIC, 8
- Polarity, 14
- Remote venting, 6
- Resistor values, 9
- Return Material Authorization, 4
- Safety guidelines, 14
- Shorting wire
 - During discharge, 15
 - During shipping, 6
 - During storage, 14
- Temperature
 - Cooling methods, 13
- Temperature rise
 - Equation, 13
- Thermal Capacitance, 13
 - Equation, 13
- thermal resistance, 13
 - Equations, 13
 - Operating limits, 13
- Thermistor
 - Modeling examples, 12
- Thermistor resistance, 11
- Thread engagement, 7
 - Guidelines, 7
 - Illustration, 7
 - Maximum on module terminals, 7
- Threaded bolt length, 7

Threaded vent hole, 6	Vibration
Tightening the terminal bolts, 8	Qualification standards, 5
Torque value, 8	Warning
Unpacking modules, 4	Avoid arcing, 6
Vent hole, 6	Preventing excessive current flow, 6
Venting	Washer and cable lug thickness, 7
Hose barb used in, 6	Wire temperature, 6
Remote, 6	

Please contact Maxwell Technologies directly for any technical specifications critical to application. All products featured on this user manual are covered by the following U.S. patents and their respective foreign counterparts: 6643119, 7102877, 7203056, 7295423, 7342770, 7352558, 7384433, 7440258, 7492571, 7508651, 7580243, 7791860, 7791861, 7816891, 7859826, 7883553, 7935155, 7859826, 7883553, 7935155, 8072734, 8098481, 8279580 and patents pending.

MAXWELL TECHNOLOGIES, MAXWELL, MAXWELL CERTIFIED INTEGRATOR, ENABLING ENERGY'S FUTURE, BOOSTCAP, C CELL, D CELL, CONDIS, RAD-PAK, DuraBlue and their respective designs and/or logos are either trademarks or registered trademarks of Maxwell Technologies, Inc. and may not be copied, imitated or used, in whole or in part, without the prior written permission Maxwell Technologies, Inc. All contents copyright © 2015 Maxwell Technologies, Inc. All rights reserved. No portion of these materials may be reproduced in any form, or by any means, without prior written permission from Maxwell Technologies, Inc.