

CEFM101-G Thru. CEFM105-G

Reverse Voltage: 50 to 600 Volts

Forward Current: 1.0 Amp

RoHS Device

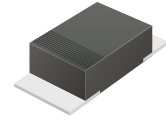

Features

- Ideal for surface mount applications.
- Easy pick and place.
- Plastic package has Underwriters Lab. flammability classification 94V-0.
- Super fast recovery time for high efficient.
- Built-in strain relief.
- Low forward voltage drop.

Mechanical data

- Case: Molded plastic, JEDEC SOD-123/Mini SMA.
- Terminals: Solderable per MIL-STD-750, method 2026.
- Polarity: Indicated by cathode band.
- Weight: 0.018 grams approx.

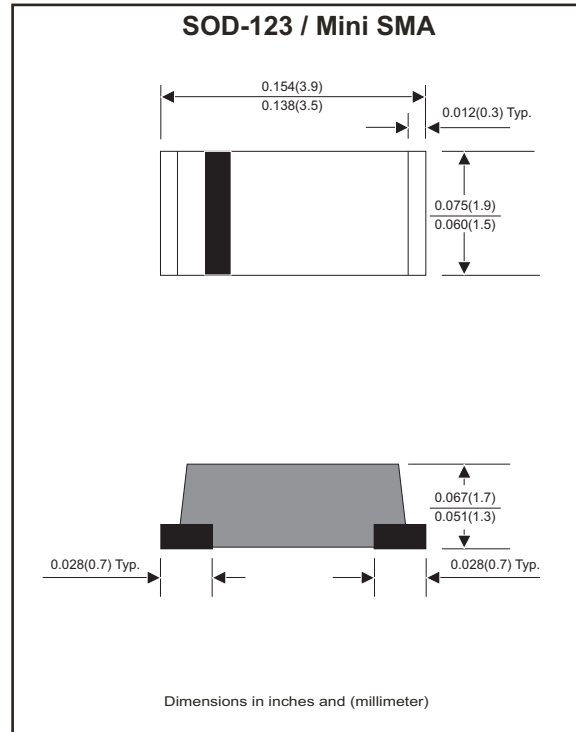

Maximum Ratings (at TA=25°C unless otherwise noted)

Parameter	Symbol	CEFM 101-G	CEFM 102-G	CEFM 103-G	CEFM 104-G	CEFM 105-G	Unit
Repetitive peak reverse voltage	V_{RRM}	50	100	200	400	600	V
Continuous reverse voltage	V_R	50	100	200	400	600	V
RMS Voltage	V_{RMS}	35	70	140	280	420	V
MAX. Forward surge current	I_o	1.0					A
MAX. Forward voltage at $I_F=1.0A$	V_F	0.875			1.25	1.75	V
MAX. Forward surge current, 8.3ms single half sine-wave superimposed on rated load (JEDEC method)	I_{FSM}	25					A
MAX. Reverse recovery time, (Note 1)	T_{rr}	25					nS
MAX. Reverse current	$V_R=V_{RR}$ $T_J=25^\circ C$	5.0					μA
	$V_R=V_{RR}$ $T_J=125^\circ C$	100					
TYP. Diode junction capacitance (f=1MHz and applied 4V DC reverse voltage)	C_J	15					pF
Operating junction temperature	T_J	-55 to +150					$^\circ C$
Storage temperature range	T_{STG}	-65 to +175					$^\circ C$

Note 1: Reverse recovery time test Condition, $I_F=0.5A$, $I_R=1.0A$, $I_{RR}=0.25A$

Rating and Characteristic Curves (CEFM101-G Thru. CEFM105-G)

Fig.1 - Typical Forward Characteristics

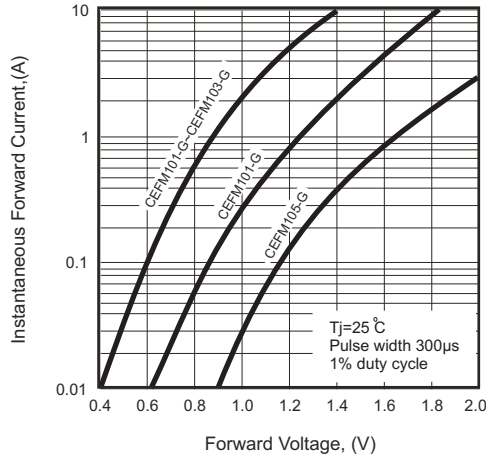

Fig. 2 - Typical Forward Current Derating Curve

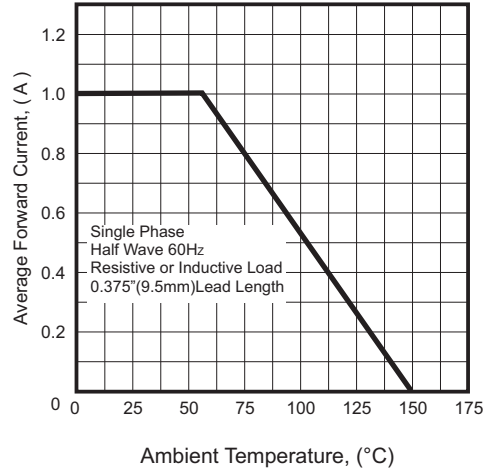
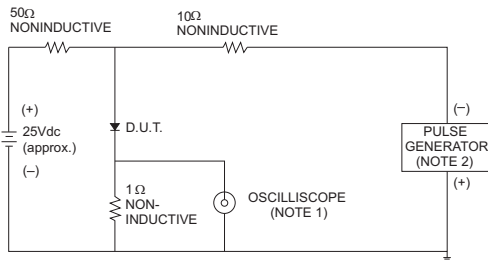

Fig. 3 - Test Circuit Diagram and Reverse Recovery Time Characteristics



NOTES: 1. Rise Time= 7ns max., Input Impedance= 1 megohm.22pF.
2. Rise Time= 10ns max., Source Impedance= 50 ohms.

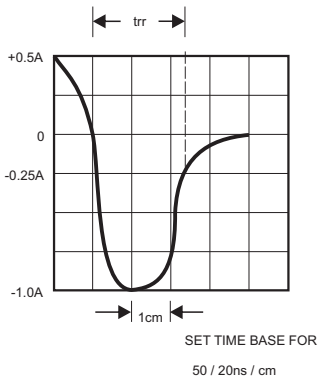

Fig. 4 - Maximum Non-Repetitive Forward Surge Current

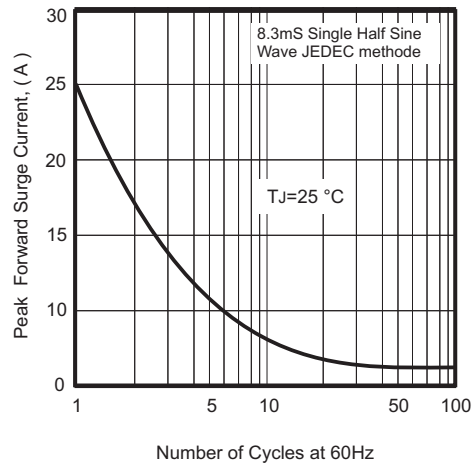
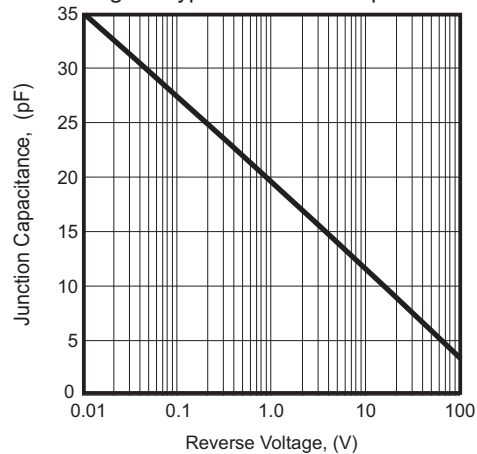
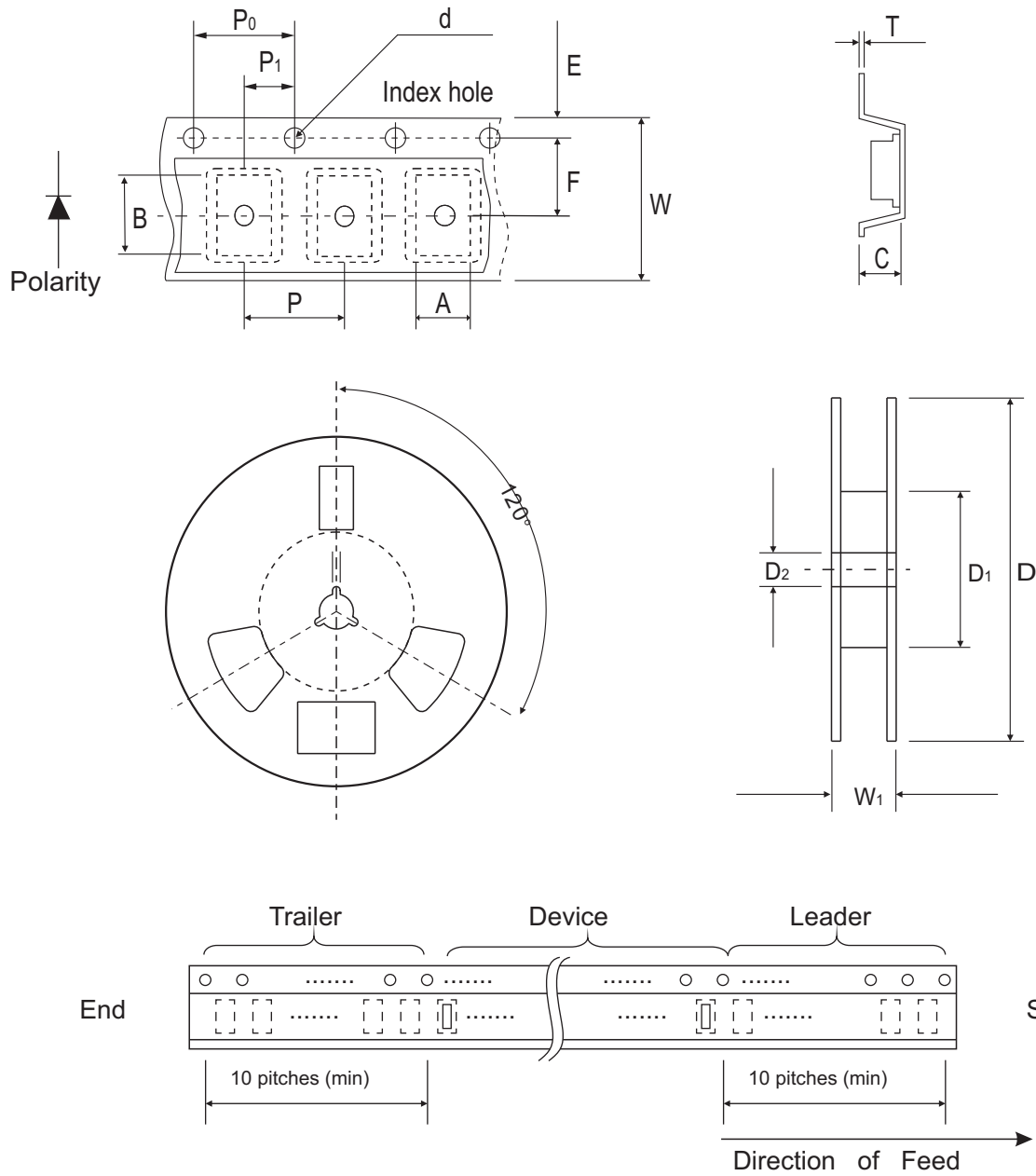

Fig.5 - Typical Junction Capacitance



Reel Taping Specification



Mini-SMA/SOD-123	SYMBOL	A	B	C	d	D	D1	D2
	(mm)	1.90 ± 0.10	3.90 ± 0.10	1.68 ± 0.10	1.50 ± 0.10	178 ± 2.00	62.0 MIN.	13.0 ± 0.50
	(inch)	0.075 ± 0.04	0.154 ± 0.04	0.066 ± 0.04	0.059 ± 0.004	7.00 ± 0.079	2.440 MIN.	0.512 ± 0.020

Mini-SMA/SOD-123	SYMBOL	E	F	P	P0	P1	T	W	W1
	(mm)	1.75 ± 0.10	3.50 ± 0.10	4.00 ± 0.10	4.00 ± 0.10	2.00 ± 0.10	0.23 ± 0.10	8.00 ± 0.30	11.40 ± 1.0
	(inch)	0.069 ± 0.004	0.138 ± 0.004	0.157 ± 0.004	0.157 ± 0.004	0.079 ± 0.004	0.009 ± 0.004	0.315 ± 0.012	0.449 ± 0.004

Marking Code

Part Number	Marking Code
CEFM101-G	E1
CEFM102-G	E2
CEFM103-G	E3
CEFM104-G	E4
CEFM105-G	E5



XX = Product type marking code

Suggested PAD Layout

SIZE	Mini-SMA/SOD-123	
	(mm)	(inch)
A	3.30	0.130
B	1.40	0.055
C	1.90	0.075
D	4.70	0.185
E	1.90	0.075

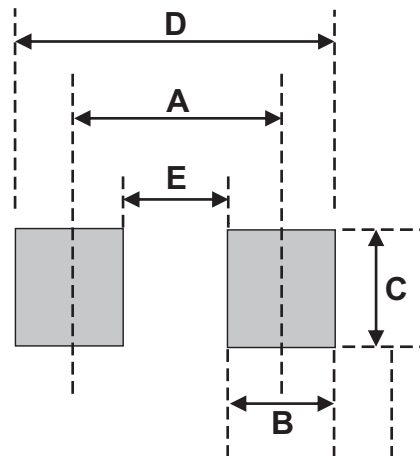

Standard Packaging

Case Type	Qty per Reel	Reel Size
	(Pcs)	(inch)
Mini-SMA/SOD-123	2500	7